

PRODUCT SPECIFICATIONS

GS-72-F FOOD GRADE STRAINER

STANDARD FEATURES

- 316-L Stainless Steel
- 3PH 1/2 HP Motor
- Wedgewire Screen
- PEEK Stationary
- Wiper Blade
- 2" tri-clamp connections
- 150 PSI Rating
- 2-3 Week Lead Time

AVAILABLE OPTIONS

- 1 PH, air, XP
- Perforated Screen
 - Delrin -Teflon
- 2" Flanged Connections
- Mobile Stand
- Monthly Test Lease

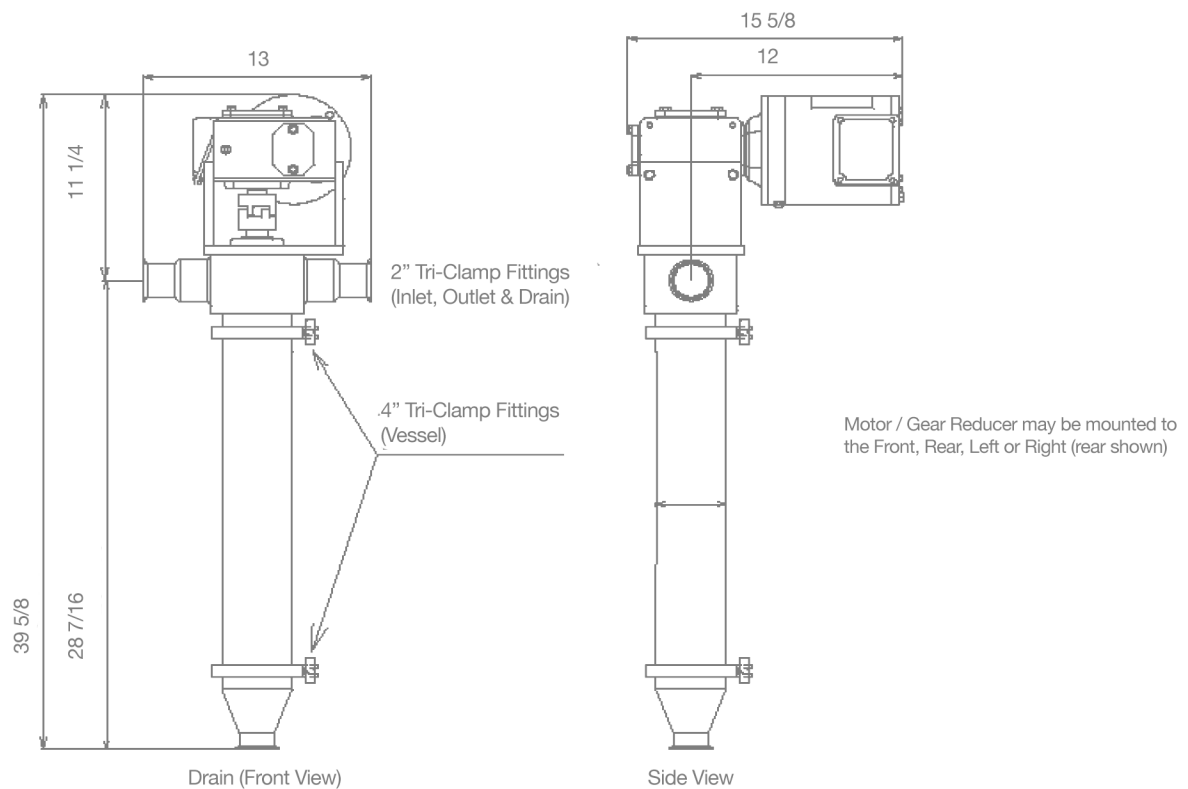

800.801.4977

www.spencerstrainer.com